

Question (5)

- (a) Define the following items: acceptance angle, critical angle, and Numerical Aperture (NA).
- (b) A silica optical fiber with a core diameter large enough to be considered by ray theory analysis has a core refractive index of 1.5 and a cladding refractive index of 1.47. Determine:
- (1) The critical angle of the core-cladding interface.
  - (2) The NA for the fiber.
  - (3) The acceptance angle in air for the fiber.

Question (6)

- (a) State, aided with figures, the required steps to determine the wavelength and the operating frequency of the transmitting signal using a horn antenna.
- (b) Define polarization and state its main types?
- (c) Aided with figures, State the required steps to determine the polarization of the antenna.

*Best Wishes of Success*

---

Course Title: Tests and Electronic measurements  
Date: 26/6/2011 (Second term)Course Code: EEC  
Allowed time: 3 hrsYear: 4<sup>th</sup>  
No. of Pages: (2)

Remarks: (answer the following questions... assume any missing data... answers should be supported by sketches... Neat answers and boxed results are appreciated)

Question (1)

- (a) Sketch the block diagram of PCM (transmitter and receiver).
- (b) What is the function of the following:-
- Shift registers in transmitter and receiver.
  - Latch circuit in both transmitter and receiver.
  - AND gate in receiver module.
- (c) Sketch the output waveform at the following terminals:-
- Ramp output.
  - PCM output.
  - Counter divide by 8.
  - AND gate output.
- (d) An audio CD has mp3 file of sampling rate 44.1 kHz with a bit depth of 16, CD tracks are usually stereo, using a left and right track. Determine the bit rate of audio CD.

Question (2)

- (a) For the following bit stream 010010100, sketch waveforms representing the following:-
- Uni-Polar NRZ Format
  - Biphase Format
  - Ternary Format
- (b) What is the best line code format? Why?

Question (3)

- (a) Sketch the FSK module (Transmitter and Receiver)
- (b) Sketch the internal circuit for FSK modulator and demodulator
- (c) Using FSK demodulator circuit, aided with sketch, Find the output for the following:-
- Stream of one's
  - Bit stream of 010010

Question (4)

- (a) What are the basic components of optical fiber module?
- (b) Discuss the losses in optical fiber.
- (c) Compare between the following:-
- Single-mode and multi-mode fibers.
  - Step-index and graded index fiber.

**Problem number (1)****15 Marks**

- a- State the evolution in mobile communications and technology specifications from 1G to 4G passing through 2G and 3G systems?
- b- Draw the frequency reuse pattern and distribution for 64 cells (grid of 8x8 cells) at cluster sizes of 3, 4, 7 and 9?

**Problem number (2)****30 Marks**

For the installed BTS in the figure below, write a technical report showing the validity of this BTS. If any violations are existed, what are your recommendations to make it legal? Hint the numbers in the figure refer to the distance in meters.

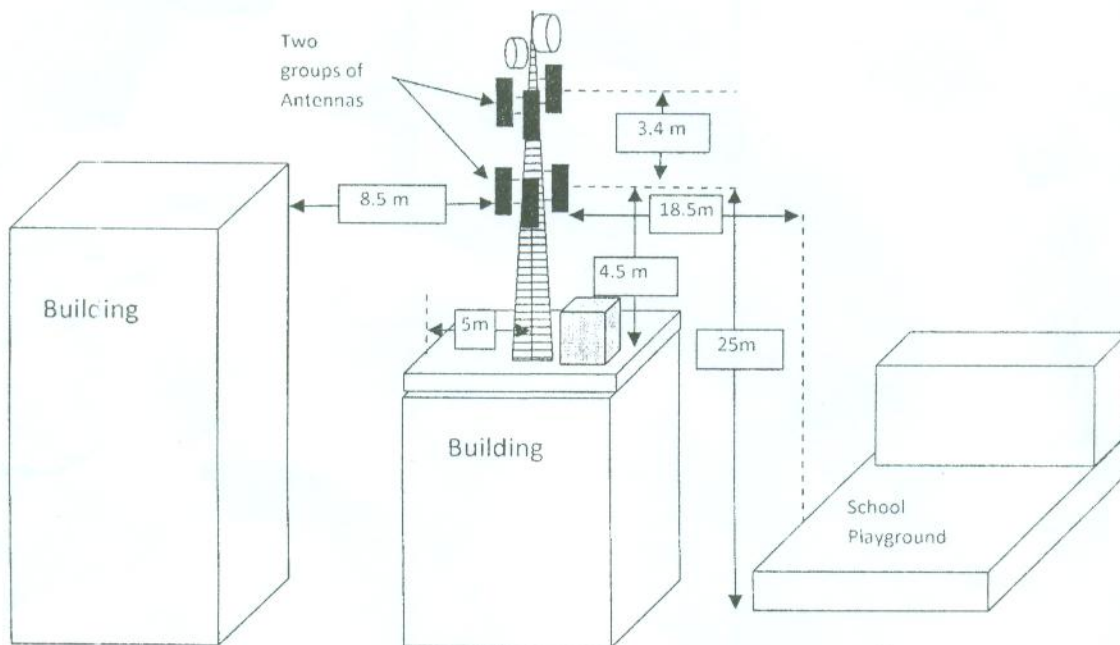
**Problem number (3)****15 Marks**

- a- Discuss the propagation problems in the mobile radio channel?
- b- Describe with sketches the sequence of operations needed for
- Location updating
  - Calls to a mobile

**Problem number (4)****15 Marks**

- a- Discuss with sketches the different types of handover?
- b- Describe the different multiple access techniques that can be used in mobile communications system?

**Problem number (5)****15 Marks**

- a- Draw the block diagram of mobile handset showing its functional blocks?
- b- Draw the network configuration in each of the circuit and packet switched domains for both 2G and 3G systems?



**Question .5**

- a) A topology consists of three routers HQ, Branch1 and Branch 2. Each router has two LANs connected to it. The network address 172.16.128.0/17 has been used to provide the IP addressing for the entire network. VLSM has been used to subnet the address space **incorrectly**. You will need to **troubleshoot** the addressing that has been assigned for each subnet to determine where errors are present and then determine the correct addressing assignments, where needed.

(After your analysis, write this table again, underline the wrong parts, and write the correction above it)

Subnet	Number of IP Addresses Needed	Network Address
HQ LAN1	16,000	172.16.128.0/19
HQ LAN2	8,000	172.16.192.0/18
Branch1 LAN1	4,000	172.16.224.0/20
Branch1 LAN2	2,000	172.16.240.0/21
Branch2 LAN1	1,000	172.16.244.0/24
Branch2 LAN2	500	172.16.252.0/23
Link from HQ to Branch1	2	172.16.254.0/28
Link from HQ to Branch2	2	172.16.254.8/30
Link from Branch1 to Branch2	2	172.16.254.8/30

- b) For the network shown:

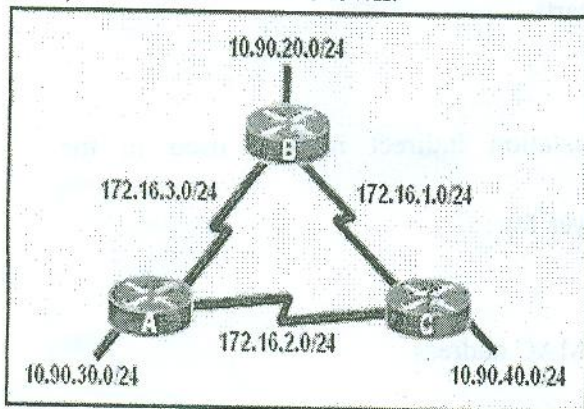

Atah ip route

Codes: C - connected, S - static, I - IGRP, R - RIP, M - mobile, S - BGP

```

10.0.0.0/24 is subnetted, 1 subnets
C    10.90.30.0 is directly connected, FastEthernet0/0
172.16.0.0/24 is subnetted, 3 subnets
R    172.16.1.0 [120/1] via 172.16.3.1, 00:00:25, Serial10/0/0
    [120/1] via 172.16.2.2, 00:00:10, Serial10/0/1
C    172.16.2.0 is directly connected, Serial10/0/1
C    172.16.3.0 is directly connected, Serial10/0/0
  
```

RIPv1 is configured as the routing protocol for all routers. The following commands below are used on each router:

```

router rip
network 10.0.0.0
network 172.16.0.0
  
```

After this the result of *show ip route* command on Router A was as shown above.

- The LANs of router B and C didn't appear in the routing table. Why?
  - The network 172.16.1.0 appeared with its correct mask. Why?
  - Write the commands that should be applied to make the entire network connected.
- c) Pure distance vector protocol suffers from the problem of **routing loops**. ONLY State what is meant by a routing loop and two solutions the RIP use to avoid it.

Assoc. Prof. Salah Khamis



Computer Communication Networks	Course Code: EEC4231	Year: 4 <sup>th</sup>
Date: Jun, 19 <sup>th</sup> 2011 (Second Term)	Allowed Time: 3 hrs	No. of Pages: (2)

**Answer the following Questions:**

**Question 1:**

- What are parameters that govern the choice of a certain ARQ scheme?
- Using diagrams demonstrate the operation of each scheme?
- Explain using net sketches the difference between:
  - Gate way – Router
  - Bridge – Hub

**Question 2:**

- What are network access protocol classes? Give examples for each class and put your answers in a tree form.
- Compare the performance of pure ALOHA and slotted ALOHA protocols. Deduce a formula for channel utilization in both cases.
- Explain the operation of CSMA/CD, Token passing Ring, and polling methods aids of diagrams and flow charts.

**Question 3:**

- Draw using net sketches the translation indirect method used in the presentation layer.
- Explain the duties of data transport layer for :
  - End – to – End delivery
  - Reliable delivery
- Differentiate between IP address and MAC address.

**Question 4:**

A computer network's flow control is to be chosen .the propagation delay of the network links were monitored and found to be 10 ms/km on average. The bit rate is 10 Mbps. The average cable length used was 700 m. the packet size is fixed at 53 bytes on this network (ATM networks use this packet size) If the packet loss rate was found to be 11%,find the most suitable ARQ mechanism from what stated below for such a network according to these design considerations:

- ACK or NAK packet size is negligible.
- Timeout occurs after 1.06 round trip time.
- Continuous ARQ uses a window of 8 packets.
- A lost packet occurred after the forth packet in 40 % of windowed observations and after the sixth packet in the rest of windowed observations.

### Question Three

1- Image processing is used often in industrial applications for detecting missing components in product assembly. The method is to store a correct image that corresponds to the correct assembly; this image is then operated with the image of the sample product. Write two possible operations to detect possible differences between these two images then perform those operations using the required Matlab code.

2- Draw the color cube for the RGB model, and then complete the following table

R	G	B	Color
0	0	0	-----
255	255	0	-----
255	0	255	-----
0	0	255	-----
255	255	255	-----

3- The following table gives the number of pixels at each of the grey levels in an image with those grey values only:

0	1	2	3	4	5	6	7	8	9	10	11	12	13	14	15
20	40	60	75	80	75	65	55	50	45	40	35	30	25	20	30

Draw the histogram corresponding to these grey levels, and then perform histogram equalization and draw the resulting histogram.

### Question Four

1-Two images  $f(x,y)$  and  $g(x,y)$ , have histograms  $h_f$  and  $h_g$ . Explain how to obtain the histogram in the following cases:  $f(x,y) + g(x,y)$ , and  $f(x,y) - g(x,y)$ . 1- Give three classification digital images according to color, appearance

2- Given an alphabet  $A = (a, b, c, d, e)$  and its probability (0.4, 0.2, 0.2, 0.1, 0.1) for each letter respectively, there are exactly two possible "shapes" of Huffman trees for A and its probability distribution, Draw two Huffman trees with different shapes?

3- Explain the meaning of the following terms according to MPEG Video compression

- Temporal compression algorithms - Motion estimation - Group of pictures

### Question Five

1- Explain the basic idea of CCD camera image capturing system (use necessary drawing if possible)

2-Using the reflected gray code (RGC), show the decimal numbers between (0-15) that are represented by 4 bits.

	-3	2	0	-2	-1	0	0
4	-1	-2	0	0	0	0	0
0	3	0	0	0	0	0	0
0	-1	1	0	0	0	0	0
1	0	0	0	0	0	0	0
0	0	0	0	0	0	0	0
0	0	0	0	0	0	0	0
0	0	0	0	0	0	0	0

3-Given the above table of DCT coefficients, what is the zig-zag order of these coefficients?

مع أطيب التمنيات بالتوفيق - د. حاتم عبد القادر

**Answer all Questions**

**Question One**

1- Explain what is the Geometric mean filter and Alpha trimmed mean filter , then write a Matlab code to implement each one of those nonlinear filters(state any assumption you use in the code).

3- A 4\*4 gray scale original image passes through three spatial linear invariant filters resulting in three filtered images

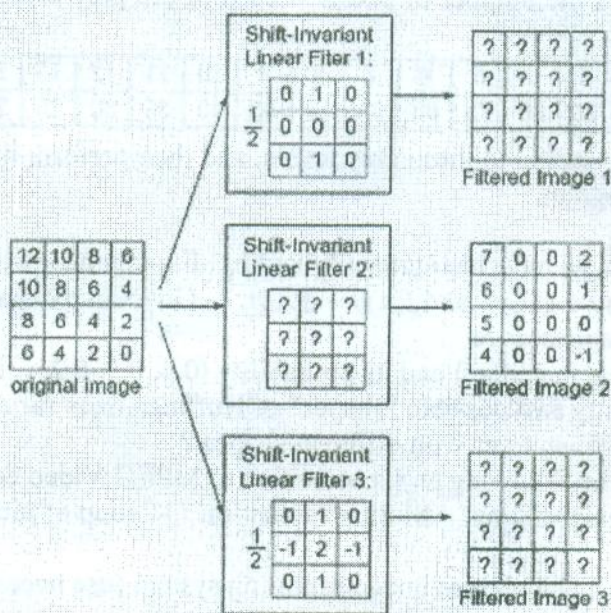

- Compute Filtered Image 1 (Use zero-padding of the original image)
- Compute the values of each element in filter 2 ((Use zero-padding of the original image)
- Compute Filtered Image 3 (Use zero-padding of the original image).

**Question Two**

- Draw a schematic diagram for un-sharp masking then write a Matlab code to implement this type of masking (state any assumption you use in the code).
- Is the 3\*3 median filter separable? That is, can this filter be implemented by 3\*1 filter followed by 1\*3 filter? Give an example
- Compute the discrete Fourier transform (DFT) of the following 2D function. Show all work, equations, and coefficients. Hint: you can compute the coefficients for a four-point DFT, and use them over and over again.

$$f(i, j) = \begin{bmatrix} 1 & 1 & 1 & 1 \\ 0 & 0 & 0 & 0 \\ 0 & 0 & 0 & 0 \\ 0 & 0 & 0 & 0 \end{bmatrix}$$

الاسئلة

عريف

**Problem number (1)**

**15 Marks**

- a- State the evolution in mobile communications and technology specifications from 1G to 4G passing through 2G and 3G systems?
- b- Draw the frequency reuse pattern and distribution for 64 cells (grid of 8x8 cells) at cluster sizes of 3, 4, 7 and 9?

**Problem number (2)**

**30 Marks**

For the installed BTS in the figure below, write a technical report showing the validity of this BTS. If any violations are existed, what are your recommendations to make it legal? Hint the numbers in the figure refer to the distance in meters.

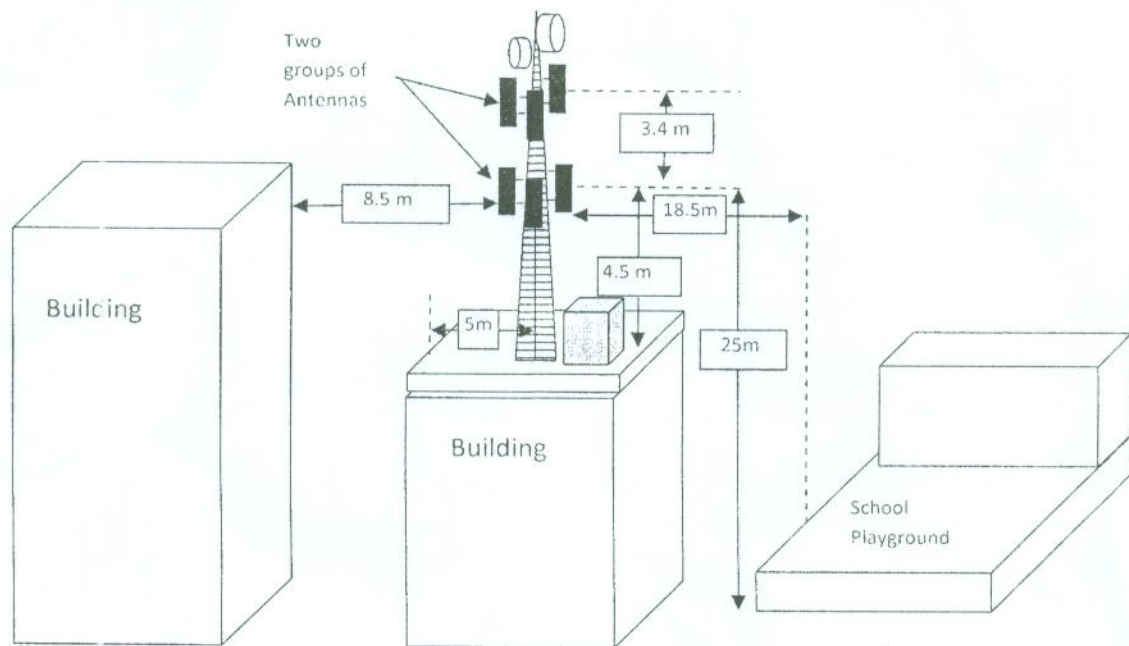

**Problem number (3)**

**15 Marks**

- a- Discuss the propagation problems in the mobile radio channel?
- b- Describe with sketches the sequence of operations needed for
  - i. Location updating
  - ii. Calls to a mobile

**Problem number (4)**

**15 Marks**

- a- Discuss with sketches the different types of handover?
- b- Describe the different multiple access techniques that can be used in mobile communications system?

**Problem number (5)**

**15 Marks**

- a- Draw the block diagram of mobile handset showing its functional blocks?
- b- Draw the network configuration in each of the circuit and packet switched domains for both 2G and 3G systems?



- b- For a multi-channel optical amplitude modulation system consisting of  $N=3$  channels, where the intermodulation products appear, find the number of triple beat terms IM products, the number of the two-tone terms IM products, the number of the IM triple beat products around the second carrier, and the number of the two-tone products around the second carrier. You can make use of the following equations:

$$D_{1,2} = \frac{1}{2} \left\{ N - 2 - \frac{1}{2} [1 - (-1)^N] (-1)^r \right\}$$

$$D_{1,1,1} = \frac{r}{2} (N - r + 1) + \frac{1}{4} \left\{ (N - 3)^2 - 5 - \frac{1}{2} [1 - (-1)^N] (-1)^{N+r} \right\}$$

- c- What are the factors that affect the rise time budget in optical communication systems? What is the significance of this budget?

**Question 5: (Answer two points only)**

- Sketch the block diagram of the optical OFDM system and explain its main advantages.
- Compare between SONET and SDH networks.
- State one of the problems in digital optical communication systems with a method to solve this problem.

**Question 6: (Answer two points only)**

- Assume a state of failure in an optical network and explain how this failure is solved.
- What is the difference between a multiplexer and a demultiplexer? Explain how you can build both in optical communication systems.
- Explain the process of building large couplers from small couplers in optical communications.

Answer the following questions:

**Question 1: (Answer two points only)**

- a- Explain with the aid of sketches the idea of WDM. What is meant by DWDM?
- b- What is the difference between a passive star and an active repeater in a fiber network? Illustrate with sketches.
- c- How can an analog signal be transmitted with a laser diode? Show how the laser modulation is performed.

**Question 2: (Answer two points only)**

- a- How can you build a Mach-Zhender multiplexer from couplers and phase shifters? Illustrate your answer with equations and block diagrams.
- b- How can the UV light be used to create an optical filter? Illustrate your answer with sketches?
- c- Can an optical demultiplexer be built with the aid of an optical filter? Explain how.

**Question 3: (Answer two points only)**

- a- Define the dynamic range of an optical Bus network. What is the significance of this parameter?
- b- From the loss point of view? Is it preferable to communicate with a Bus optical network or a Star network? Why?
- c- Explain how you can make the link power Budget in optical communications.

**Question 4: (Answer two points only)**

- a- Consider an optical link that consists of a LED with output power of -13 dB coupled into fiber flylead. A silicon PIN receiver with sensitivity of -42 dB. Two connectors at the ends; each has loss of 1 dB. The fiber attenuation is 3.5 dB/Km. The system margin is 6 dB. The system bit rate is 20 Mb/s. Find the length of the transmission path. Represent the link power budget graphically.

Question (4)

(a) Consider the code with the following P matrix

$$P = \begin{bmatrix} 1 & 1 & 0 \\ 0 & 1 & 1 \\ 1 & 0 & 1 \end{bmatrix}$$

- (i) How many code words could be obtained in this code?
- (ii) Which of the following is a code word; (100110), (010110)?
- (iii) A code word of the form (X01011); Is X= 0 or 1? What is the weight of this codeword?

(b) Check whether the received signal "0010111010101100" is error-free or not using Hamming code (16, 11) where the Hamming bits are in positions 1, 2, 4, 8, and 16.

(c) Determine the parity check matrix for a (7, 4) code, using P matrix as follow:

$$P = \begin{bmatrix} 1 & 1 & 1 \\ 1 & 1 & 0 \\ 1 & 0 & 1 \\ 0 & 1 & 1 \end{bmatrix}$$

What is the information message if the received codeword is "1110001".

Question (5)

- (a) Describe the continuous communication channel. Give its capacity, and its implications.
- (b) A terminal is used to enter alphanumeric data into a computer through a telephone channel of 3400 Hz. It is found that the obtained channel rate is 14929 bit/sec. Determine
  - (i) S/N in dB.
  - (ii) If the channel bandwidth is doubled, what will be the required S/N for the same channel rate?
- (c) Construct a convolution encoder with the commutator samples  $C_1 = D_1$ ,  $C_2 = D_1 \oplus D_2$ , and  $C_3 = D_1 \oplus D_2 \oplus D_3$ . The data input stream is 1011. Find the message coded by the encoder.

*Best Wishes of Success*

 Course Title: Information Theory  
 Date: 15/6/2011 (Second Term)

 Course Code: EEC4237  
 Allowed time: 3 hrs

 Year: 4<sup>th</sup>  
 No. of Pages: (2)

Remarks: (answer the following questions, assume any missing data, answers should be supported by sketches, Neat answers and boxed results are appreciated)

**Question (1)**

- (a) In a piece of text only the following letters are used with the number of times each letter appears in given brackets, A (183), B (183), C (183), D (108), E (108), F (67), G (67), H (67), I (34). Determine the amount of information in the text.
- (b) Consider the source modelled by the graph shown below. Find the average information content per symbol in messages containing one, and two symbols, Comment.

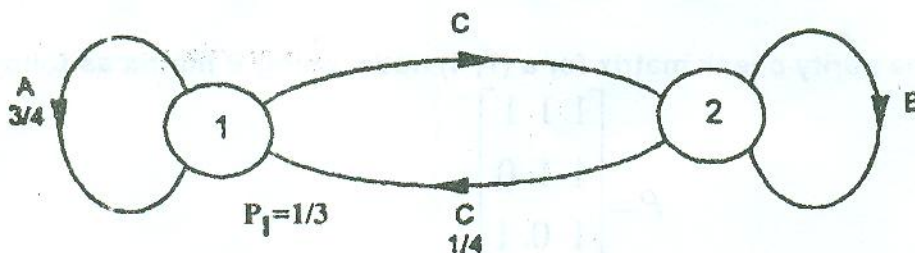
**Question (2)**

- (a) Define the following terms: Prefix code, non-singular code, unique decodable code, and instantaneous code. Give an example for each.
- (b) A source with seven symbols with the probabilities  $[P(x)] = [0.4, 0.2, 0.12, 0.08, 0.08, 0.08, 0.04]$ . Determine the following:-
- Huffman code using 2-symbols at a time and evaluate the code
  - Repeat (i), using 3-symbols at a time.
  - Comment on your results obtained from (i) and (ii).

**Question (3)**

- (a) Show that the mutual information of a channel is symmetric.
- (b) Prove that  $I(X_i; Y_j) = H(X_i) - H(X_i / Y_j)$ .
- (c) A transmission channel has the following matrix;

$$\begin{bmatrix} \dots & 0.08 & 0.13 \\ 0.06 & \dots & 0.09 \\ 0.14 & 0.12 & \dots \\ \dots & 0.04 & 0.06 \end{bmatrix}$$

 With source probabilities  $[P(x)] = [0.25, \dots, 0.4, 0.17]$ . Determine the following:-

- Compare between the source efficiency and channel efficiency.
- Construct both the joint and transition matrices of the opposite type of channel.

**Question (4)**

(a) Consider the code with the following P matrix

$$P = \begin{bmatrix} 1 & 1 & 0 \\ 0 & 1 & 1 \\ 1 & 0 & 1 \end{bmatrix}$$

- (i) How many code words could be obtained in this code?
- (ii) Which of the following is a code word; (100110), (010110)?
- (iii) A code word of the form (X01011); Is X= 0 or 1? What is the weight of this codeword?

(b) Check whether the received signal "0010111010101100" is error-free or not using Hamming code (16, 11) where the Hamming bits are in positions 1, 2, 4, 8, and 16.

(c) Determine the parity check matrix for a (7, 4) code, using P matrix as follow:

$$P = \begin{bmatrix} 1 & 1 & 1 \\ 1 & 1 & 0 \\ 1 & 0 & 1 \\ 0 & 1 & 1 \end{bmatrix}$$

What is the information message if the received codeword is "1110001".

**Question (5)**

(a) Describe the continuous communication channel. Give its capacity, and its implications.

(b) A terminal is used to enter alphanumeric data into a computer through a telephone channel of 3400 Hz. It is found that the obtained channel rate is 14929 bit/sec. Determine

- (i) S/N in dB.
- (ii) If the channel bandwidth is doubled, what will be the required S/N for the same channel rate?

(c) Construct a convolution encoder with the commutator samples  $C_1 = D_1$ ,  $C_2 = D_1 \oplus D_2$ , and  $C_3 = D_1 \oplus D_2 \oplus D_3$ . The data input stream is 1011. Find the message coded by the encoder.



Course Title: Information Theory

Course Code: EEC4237

Year: 4<sup>th</sup>

Date: 15/6/2011 (Second Term)

Allowed time: 3 hrs

No. of Pages: (2)

Remarks: (answer the following questions, assume any missing data, answers should be supported by sketches, Neat answers and boxed results are appreciated)

Question (1)

- (a) In a piece of text only the following letters are used with the number of times each letter appears in given brackets, A (183), B (183), C (183), D (108), E (108), F (67), G (67), H (67), I (34). Determine the amount of information in the text.
- (b) Consider the source modelled by the graph shown below. Find the average information content per symbol in messages containing one, and two symbols, Comment.

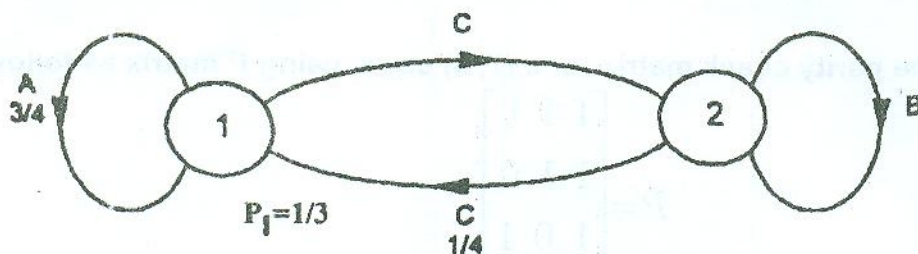
Question (2)

- (a) Define the following terms: Prefix code, non-singular code, unique decodable code, and instantaneous code. Give an example for each.
- (b) A source with seven symbols with the probabilities  $[P(x)] = [0.4, 0.2, 0.12, 0.08, 0.08, 0.08, 0.04]$ . Determine the following:-
- Huffman code using 2-symbols at a time and evaluate the code
  - Repeat (i), using 3-symbols at a time.
  - Comment on your results obtained from (i) and (ii).

Question (3)

- (a) Show that the mutual information of a channel is symmetric.
- (b) Prove that  $I(X_i; Y_j) = H(X_i) - H(X_i | Y_j)$ .
- (c) A transmission channel has the following matrix;

$$\begin{bmatrix} \dots\dots & 0.08 & 0.13 \\ 0.06 & \dots\dots & 0.09 \\ 0.14 & 0.12 & \dots\dots \\ \dots\dots & 0.04 & 0.06 \end{bmatrix}$$

With source probabilities  $[P(x)] = [0.25, \dots, 0.4, 0.17]$ . Determine the following:-

- Compare between the source efficiency and channel efficiency.
- Construct both the joint and transition matrices of the opposite type of channel.

**Question 5 (17 Marks)**

- a) Aided with the balanced amplifier configuration, deduce its scattering coefficients  $S_{11}$  and  $S_{21}$ .  
b) A GaAs MESFET balanced amplifier has the following parameters:

**MESFET a:**

Reflection coefficients:  $S_{11a} = 0.60 \angle 60^\circ$ ,  $S_{22a} = 0.65 \angle 50^\circ$ .

Forward transmission coefficient:  $S_{21a} = 7.5 \angle 180^\circ$ .

**MESFET b:**

Reflection coefficients:  $S_{11b} = 0.8 \angle 50^\circ$ ,  $S_{22b} = 0.75 \angle 30^\circ$ .

Forward transmission coefficient:  $S_{21b} = 8.0 \angle 175^\circ$ .

- i) Calculate the input and output reflection coefficients of the balanced amplifier.  
ii) Compute the input and output VSWRs.  
iii) Determine the power gain in decibels for the balanced amplifier.  
iv) Calculate the linear output power capability in comparison with two MESFETs in series.

---

**You may use the following relations:**

Delta factor:  $\Delta = S_{11}S_{22} - S_{12}S_{21}$

$$\Gamma_{em} = \frac{B_\ell \pm \sqrt{B_\ell^2 - 4|C_\ell|^2}}{2C_\ell}, \quad \Gamma_{sm} = \frac{B_s \pm \sqrt{B_s^2 - 4|C_s|^2}}{2C_s}$$

$$B_\ell = 1 + |S_{22}|^2 - |S_{11}|^2 - |\Delta|^2, \quad B_s = 1 + |S_{11}|^2 - |S_{22}|^2 - |\Delta|^2$$

$$C_s = S_{11} - \Delta S_{22}^*, \quad C_\ell = S_{22} - \Delta S_{11}^*$$

$$\text{Transducer power gain } G_T = \frac{1 - |\Gamma_S|^2}{|1 - \Gamma_{in} \Gamma_S|^2} |S_{21}|^2 \frac{1 - |\Gamma_L|^2}{|1 - S_{22} \Gamma_L|^2} \quad \text{or} \quad G_T = \frac{1 - |\Gamma_S|^2}{|1 - S_{11} \Gamma_S|^2} |S_{21}|^2 \frac{1 - |\Gamma_L|^2}{|1 - \Gamma_{out} \Gamma_L|^2}$$

---

*BEST OF LUCK FOR ALL,  
Dr. Mohamed Abdel-Rahman*

Attempt all Questions

Neat answers and boxed results are appreciated

**Question 1 (17 Marks)**

- Explain the physical operation for the TWTA and state its characteristics.
- Write down the four propagating waves and discuss their main features. Also derive an expression for the power gain  $A_p$  of TWTA.
- A traveling wave tube operates under the following parameters:  
 Beam voltage  $V_o = 2.5$  kV, Beam current  $I_o = 50$  mA, characteristic impedance of the helix  $z_o = 6.75 \Omega$ , circuit length  $N = 45$  and the applied signal frequency  $f = 8$  GHz. Determine:
  - The gain parameter C.
  - The output power gain  $A_p$  in dB.
- All four propagation constants, iv) The wave equations for all four modes in exponential form.

**Question 2 (17 Marks)**

- Derive an expression for the electronic admittance of reflex klystron and discuss the condition of oscillation emphasizing its dependence with operation modes.
- A reflex klystron operates at the peak mode of  $n = 2$  with beam voltage  $V_o = 300$  V, beam current  $I_o = 20$  mA, and signal voltage  $v = 40$  V. Determine:
  - The input power in watts.
  - The output power in watts.
  - The electronic efficiency.

**Question 3 (17 Marks)**

- Derive the relation between the buncher departure angle and the catcher arrival angle and explain the bunching process. Apply it to find the optimum distance between the two cavities.
- A two identical cavity klystron amplifier operating at  $V_o = 900$  V,  $I_o = 30$  mA, frequency  $f = 8$  GHz, Gap spacing in either cavity  $d = 1$  mm, spacing between centers of cavities  $L = 4$  cm and effective shunt impedance  $R_{sh} = 40$  k $\Omega$ . Determine:
  - The electron velocity.
  - The dc transit time of electron.
  - The input voltage for maximum output voltage
  - The voltage gain in decibels.

**Question 4 (17 Marks)**

- Derive the limits of inequality,  $-\varepsilon < \frac{G_T}{G_{TU,max}} < \varepsilon$ , to ensure the usage of unilateral or bilateral case.
- A GaAs MESFET is measured to have the following S-parameters for a midrange Q-point where  $V_{DS} = 5$  V,  $I_D = 10$  mA at 10 GHz with:  $S_{11} = 0.55 \angle -150^\circ$ ,  $S_{12} = 0.04 \angle 20^\circ$ ,  $S_{21} = 2.82 \angle 180^\circ$  and  $S_{22} = 0.45 \angle -30^\circ$ . Consider the maximum tolerable error  $\varepsilon = \pm 0.5$  dB. Design the input and output matching networks for the amplifier, shown below, to operate between 50  $\Omega$  terminations source and load impedances). Hint: Also you may use the smith chart with parts of microstrip lines and the same terminations as an alternative design method.

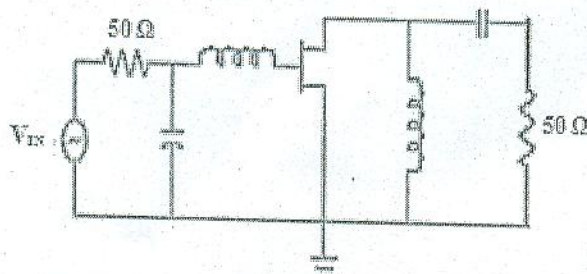

JFET Amplifier with input and output matching